



WELL DRESSED TABLES

Instruction Manual

Professional Vacuum Blender

Product WH1519 Table Top Bar Blender 240v 13amp 1.5kw

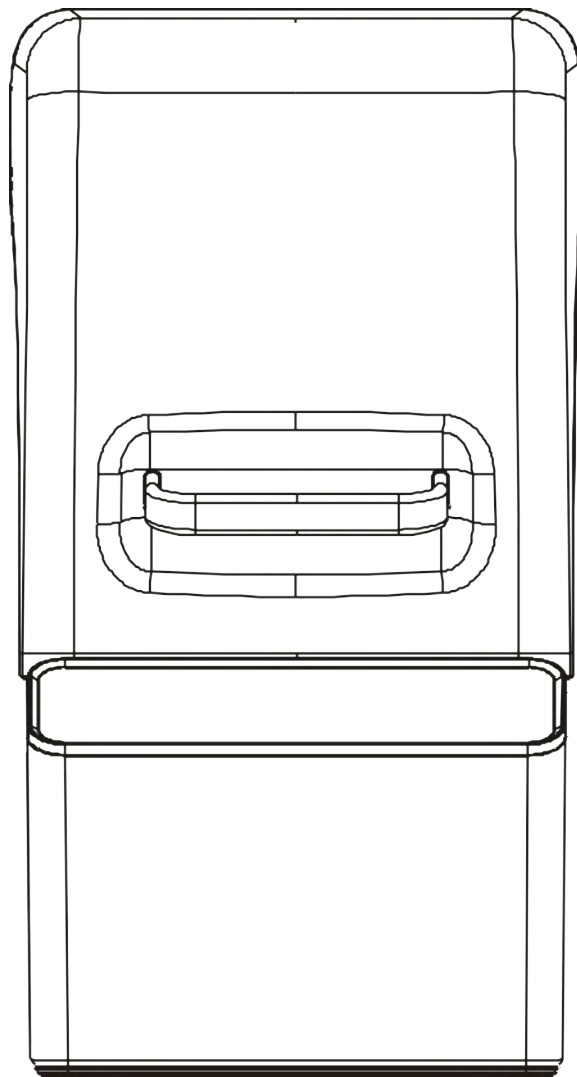

I. Product structure

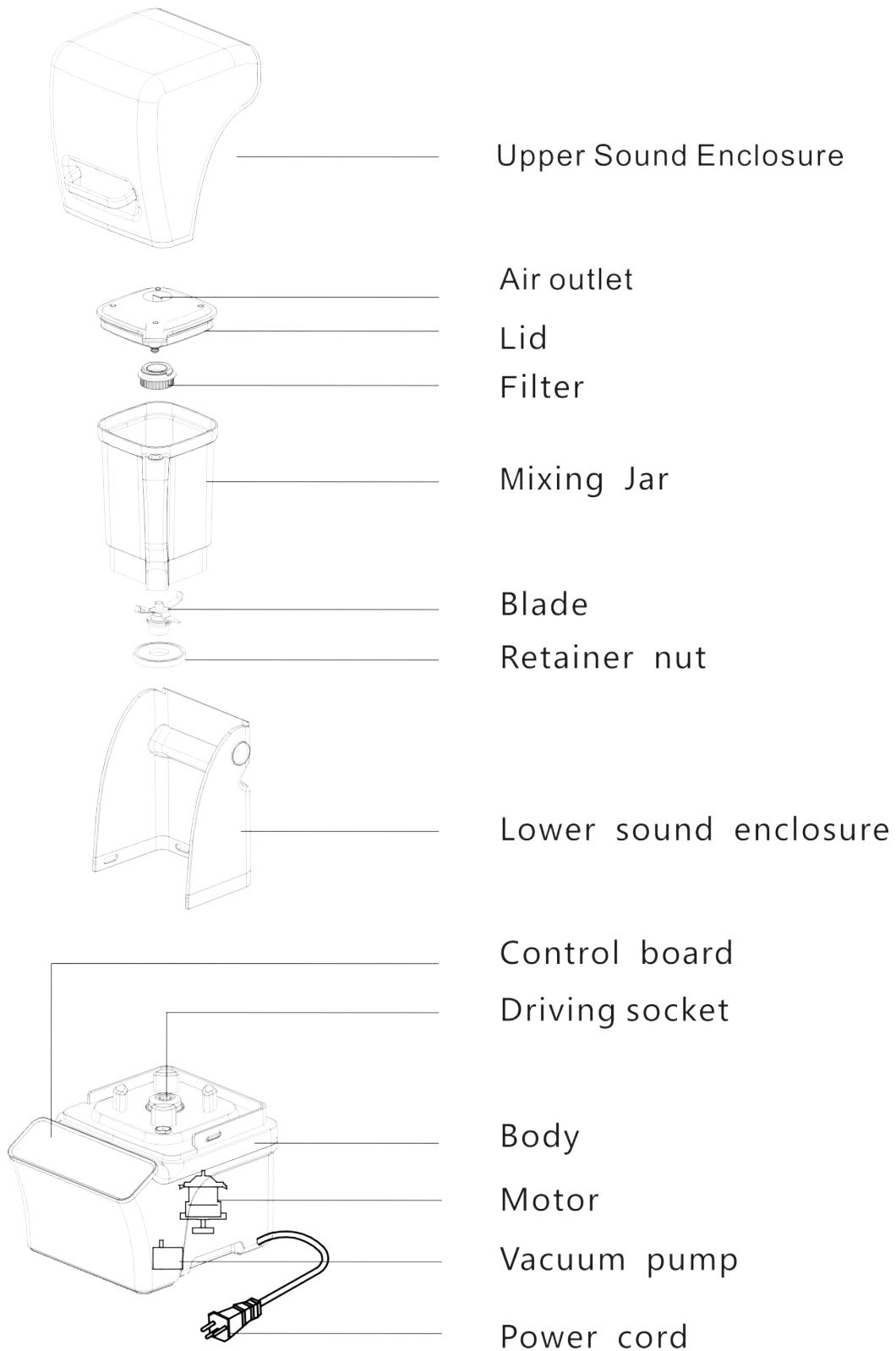

Operation

Before starting, check and make sure the followings:

The Jar is fit already securely and completely to Blender base.

The Lid is fit already on the JAR.

The Sound Enclosure is closed at position.

1. Plug on the Blender, get ready to use.
2. Fill food materials into the Jar, do not exceed the MAX marking (1.2L) on the Jar.
3. This appliance is a built-in safety device, please close the Sound Enclosure on position, then can trigger the safety switch to enable the machine to work.
4. Press on on/off button, all buttons on the control panel light up, you can adjust the speed and working time, then press on Start / Stop button to begin mixing job; you can adjust mixing speed and time during this manual control mixing procedure.
Or you can choose a pre-set program, then press on Start/Stop button to begin mixing job.
5. When finish, turn off the machine, wait until the machine stop completely, then open the Sound Enclosure, remove the Jar from the blender base for ready to enjoy your tasty creations.

● Blending Tips

- Please make sure the Lid is fit on the Jar in good position, or the vacuum job won't be processed efficiently

Instruction to the control panel



Vacuum: Press on it to start vacuum pumping only.



Pulse: Touch it to enable appliance to work at maximum speed, release it to stop.



Blending: Touch on this button for manual control mixing job. adjust speed level by speed button +/- , and mixing time by time button+/-, then press Start/stop button to mix at your favor speed and time. Still, you can also adjust speed and time during the mixing job.

Tips: this manual control mixing button doesn't vacuum pump.

▶ **Start / Stop:** After choosing a preset program, or after setting blending speed and time (manually blending mode), you can touch on this button to let the appliance start work; Touch again on it to pause the on-going program.



Smoothie: Press this button, then press **Start /stop** button, appliance vacuum pumping 1stly around 1 minute, (pumping takes a bit different time subject to quantity of food ingredients inside the jar), then go to mixing automatically.

It works at speed level 5 for 10 seconds, then transfers to speed level H for 20 seconds, then finishes automatically with sounding.



Milkshake: Press this button, then press **Start /stop** button, appliance vacuum pumping 1stly around 1 minute, (pumping takes a bit different time subject to quantity of food ingredients inside the jar), then go to mixing automatically.

It works at speed level 6 for 15 seconds, then transfer to speed level H for 20 seconds, then finish automatically with soundings



Whole juice: Press this button, then press **Start /stop** button, appliance vacuum pumping 1stly around 1 minute, (pumping takes a bit different time subject to quantity of food ingredients inside the jar), then go to mixing automatically.

This program starts to mix at speed level 5 for 20 seconds, then mixing at speed level H for 5 seconds, stop for 2 seconds, transfer to speed level 6 for 10 seconds, then transfer to speed H for 8 seconds, stop for 2 seconds, transfer to speed H for 10 seconds until finish with soundings.



Crush ice: Press this button, then press **Start /stop** button, it works at speed level H for 3 seconds, stop for 2 seconds.

Total 3 cycles, then works at speed level H for 10 seconds before finishing automatically with sounding.



Sauce: Press this button, then press **Start /stop** button, appliance vacuum pumping still around 1 minute, (pumping takes a bit different time subject to quantity of food ingredients inside the jar), then go to mixing automatically.

It works at speed level 5 for 30 seconds, transfer to speed level 4 for 30 seconds, then transfer to speed 6 for 60 seconds until finish automatically with sounding.

Tips: You can press **the Start /stop** button to stop mixing during its working course, to get your favor tiny results.

Tips:

You can choose the Vacuum button, then press on Start/stop button to process vacuum pump only.

After vacuuming and blending are finished, please lift the vacuum outlet (silicon) on the Lid for releasing the air pressure, ONLY then you can open the Lid from the Mixing jar.

● Blending Tips

- Please make sure the Lid is fit on the Jar in good position, or the vacuum job won't be processed efficiently.
- When pouring the food materials into the Jar, please be aware of the order. Please put liquid type of food and soft food material 1stly, then put ice, then add solid food materials.
- During blending process, if the food materials are been pushed toward the Jar wall, it means the RPM is too high, speed should be reduced. On the other hand, if the food materials are moving above the blade, it means the speed is too slow, needs to increase speed.
- This blender is equipped the overload protective switch in order to protect the motor in overload situations. Please wait until the motor has cooled off (can use fan to blow the base cooled off), then turn on the appliance to restart.
If the motor doesn't have enough cooling, then the machine probably can not be started or start for a short time then got shut off again.

Cleaning and Maintenance

1. When cleaning, make sure the power switch is in OFF position and pull the power plug from the electrical outlet.
 2. Cleaning the JAR: fill with clean water, turn on the PULSE switch for 10 seconds, then shut off and flush inside Jar with tap water.
 3. Use sponge or cloth to wipe the JAR and LIDS, dry them thoroughly to prevent odor or bacteria from growing.
 4. DO NOT put your hands into the JAR to clean the blades. The sharp blades will easily cause hurt to your hand. Do so only when the blades are disassembled from the JAR.
 5. Use dry cloth to wipe the transmission axle and motor base, NEVER flush with water.
- In case of difficult in cleaning, use neutral detergent to wipe, and then a dry cloth to rub clean.

SAFETY INSTRUCTIONS

1. Please read all instructions and operating procedures.
2. Make sure the power is 220V-240V 13amp
3. This appliance is not intended for use by persons (including children) with reduced physical, sensory or mental capabilities, or lack of experience and knowledge, unless they have been given supervision or instruction concerning use of the appliance by a person responsible for their safety.
4. DO NOT allow children to play with or use this appliance. Keep them at a safe distance from the appliance while operating to prevent any contact leading to an accident with the machine.
5. Please be well noted that for safety reason, the appliance won't work without the Sound enclosure to be closed at position.
6. This appliance is designed for cold mixing only, do not fill in any ingredients with temperature higher than 60 degree.
7. Ensure the Lid fits in position for processing vacuum pumping efficiently.
8. Do not put any metal items like knives, forks, spoons, etc. into the JAR.
9. Do not let the appliance dry-blending(run without any liquid inside the JAR) for more than 90 seconds, since dry-blending create extremely high temperature in a short time, may cause damage to the lubrication system of the machine.
If necessary, you can apply dry blending for one minutes, stop for 1 minutes, then apply dry blending again.
10. In case the blade looses or broken, please stop operation the blender. Then contact with distributor or factory technician.
11. When cleaning or disassemble the parts, please remember to turn off power and unplug.
12. Do not wash the Blender base with water or soak it into the water to prevent electricity shock. Do not flush water into the vacuum hole on the blender base – that may cause your appliance's malfunction.
13. Do not immerse the JAR into water or put inside a dishwashing machine, it will cause rust on the bottom of the blades assembly, then cause damage to the machine gradually.
14. Do not clean the blades with your naked hands, they are very sharp. Instead, use a brush or a thick cloth for cleaning.